

# SIMULATION MODEL OF THE LOGISTIC DISTRIBUTION IN A MEDICAL OXYGEN SUPPLY CHAIN

Francesco Costantino  
Giulio Di Gravio  
Massimo Tronci  
Department of Mechanical and Aeronautical Engineering  
University of Rome "La Sapienza"  
Via Eudossiana 18, 00184 - Rome, Italy  
E-mail: [francesco.costantino@uniroma1.it](mailto:francesco.costantino@uniroma1.it)

## KEYWORDS

Logistic supply chain, distribution, simulation, vehicle routing problem, service level, decision support system.

## ABSTRACT

Research activities on operations management in the last years are always more dedicated to supply chain and logistics optimization models.

The study belongs to this branch and describes the problems related to a re-configuration of the distribution net in a company that produces medical oxygen cylinders for Italian market. The enterprise is particularly sensible to the optimization of supplying processes due to the characteristics of its product, as any delay in the delivery could create dangerous health situation for patients.

The work has the objective to realize a software for supply chain management that could be a decision support system, analyzing strategic impacts that changes in distribution system create. In details, the model shows the differences in service level in case of closing one or more factories and the relative necessary changes in logistics net.

The paper is articulated in the following parts:

- analysis of company and construction of simulation model;
- study of classic operation research techniques to solve dynamic vehicle routing problems;
- description of possible scenes derived by strategic decision in closing factories;
- analysis of experiments and global conclusions and developments.

## RESEARCH CONTEXT

Logistic distribution represents a key factor in the competitive market. In fact, fidelization of customers and market share are necessarily related to the service level, as an increase in capacity allows higher sales, and to reduction of costs, that's to say:

- an optimal inventory management, avoiding stock-outs and minimizing immobilization;
- production programs adapted to distribution requirements;
- focused investments on supply system.

In our case study, distributive logistic is not only an operative function but a real strategic activity so, it has to be managed at direction level to be effective on company's objectives.

The study has the purpose to define a dedicated informative tool to be a support on decisional process related to the optimization of logistic chain.

In details, the proposed solution gives the possibility to stop production processes of one or more factories with an automatic optimal assignment of customers to the other production centres. The products in analysis are oxygen cylinders in both gaseous and liquid form.

Supply chain frame (fig. 1) and production process (fig. 2) are constituted of many different parts, here described:

1. primary transportation for gas distribution, from the unique raw material supplier to finished product plants. Primary transportation is different from the one from plants to customers and has independent means;
2. secondary distribution is structured to give the possibility of connecting any plant with any customer and all the customers themselves;
3. distribution links different customers categories: patients, hospitals, agencies and depots. All these customers are grouped in selling centres that place orders, depending on the demand of the single customers;
4. about cylinder filling process, it's to consider the different problems related to liquid and gaseous products;
5. at the same time, the cylinders are to be differentiated because of their coupling system and technical specifications;
6. the activation of a transport happens when a vector exhausts its load capacity or when the evaluated delivery time is higher than a fix maximum time;
7. all the customers are to be served, if possible, minimizing the distance for each single transport, so to reduce logistic costs;
8. the plants produce also industrial oxygen as raw material for other customers; but, as the logistic problems of this sector are limited, this process is not considered in the simulation model.

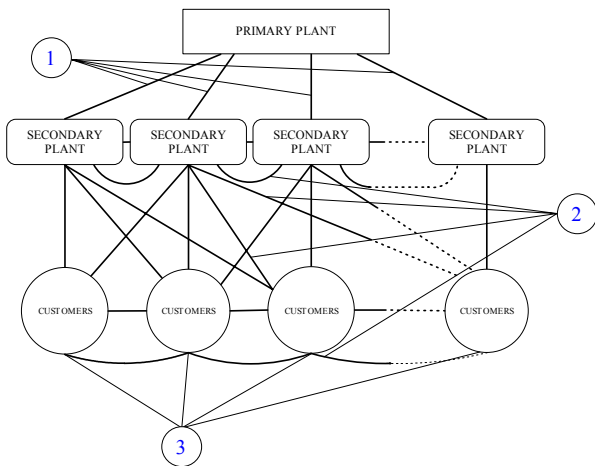

Fig. 1 – Medical oxygen supply chain

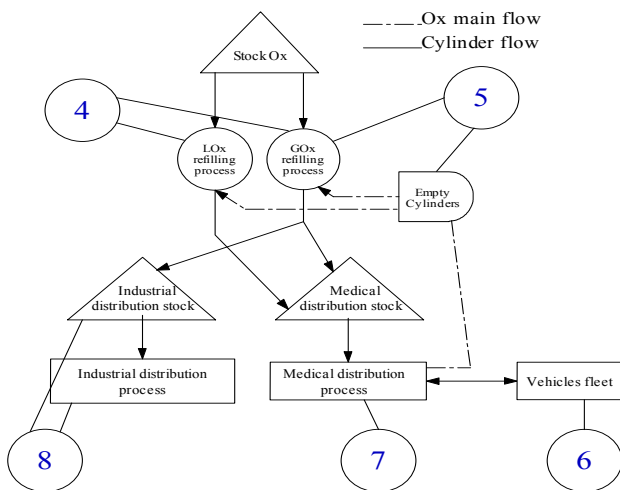

Fig. 2 – Secondary plant production process

Two further elements define the problem. First, cylinders for medical use need very short delivery time due to critical situation that a customer stock-out generates. Then, as the value of the cylinder is ten times higher than its contents, it's necessary to define a circuit of empty ones to come back. Production plants and selling centres are principally located in northern Italy, with decreasing density going to south (fig. 3). As a consequence, in the city of Trieste there is the production of raw materials. Its particular geographic position it's to consider in establishing reorder levels of the different secondary plants. It's obvious that the different distances influence supplying delivery time and so the availability of products.

### CUSTOMERS MODEL

As described, the simulation represents a high level national logistic, without modelling local distribution, and the customers are grouped and summed up in city centres. The customer is modelled as a FIFO buffer and

its stock level is continuously updated. For this particular product, a service level of 100% is needed and this explains a punctual monitoring to absolutely avoid stock-outs, together with average delivery time established by strict contractual clauses (maximum delivery time is 24 hours after a placed order).



Fig. 3 – Company territorial distribution

Following this requirements, order management is arranged with a double kanban flow (fig. 4): each full cylinder in stock has a production kanban associated that is sent as a production order anytime the respective cylinder is delivered, so to maintain a constant level of finished product in the warehouses. A movement kanban follows the cylinder to the customer.

The model represents the real transportation system, simulating the cylinders gathered together to form a load unit of 16 elements in standard dimensions, so to be easily moved by forklift in the factory. The transport to customers is effectuated by trucks of 10 load units, for a total of 160 cylinders (fig. 5).

As first step, the model assigns each customer to a particular production plant with a geographic criterion, having inside a function to redirect the orders to the other centres if the original is closed. The demand curve for selling centre is defined as the sum of the demands of each customer, based on historical series, transformed into statistic distribution. So, the customers (fig. 6) are composed of:

- empty cylinders buffer;
- full cylinders buffer;
- aggregated demand curve;
- order management activity.

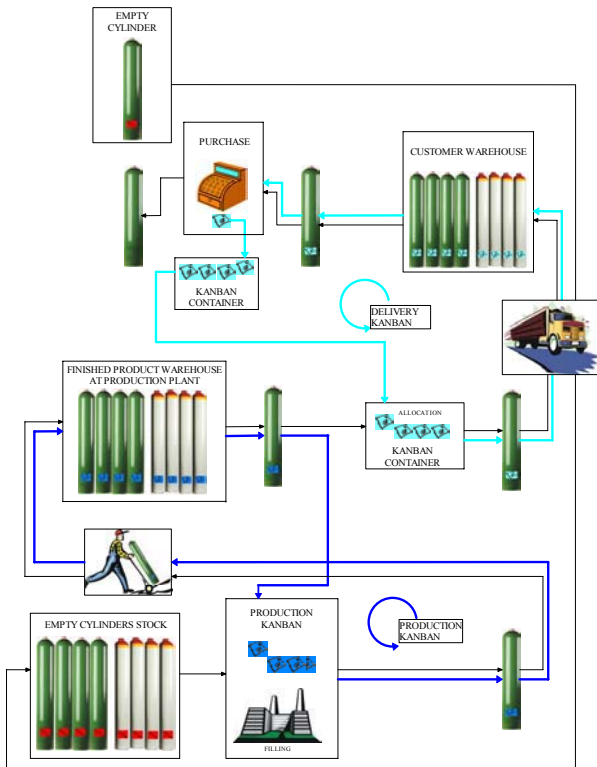

Fig. 4 – Double kanban

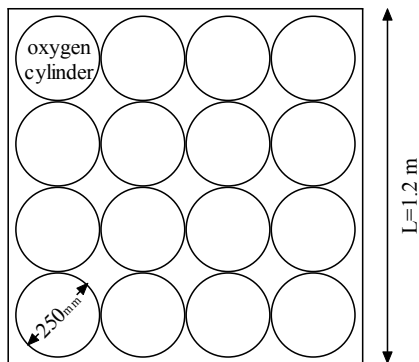

Fig. 5 – Light metal alloy load unit

Reminding the necessity of empties recovering, after delivering, an appropriate algorithm calculates the capacity left to completely fill the trucks from customer to customer. After having completed these operations, the truck is sent to the next customer, following an

appropriate sequence of visit. In fig. 7, all the activities related to the customer are defined in a flow chart.

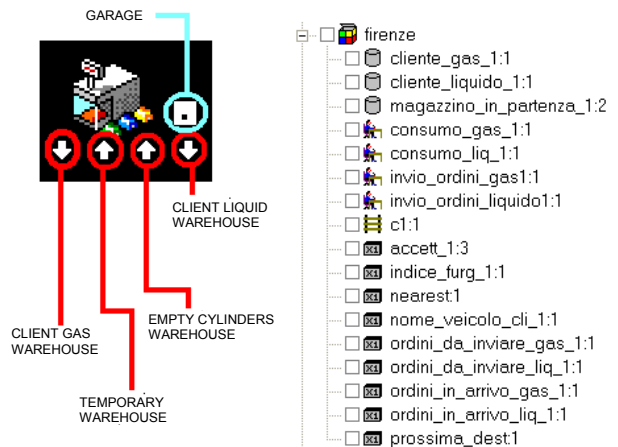

Fig 6 – Customer modelling

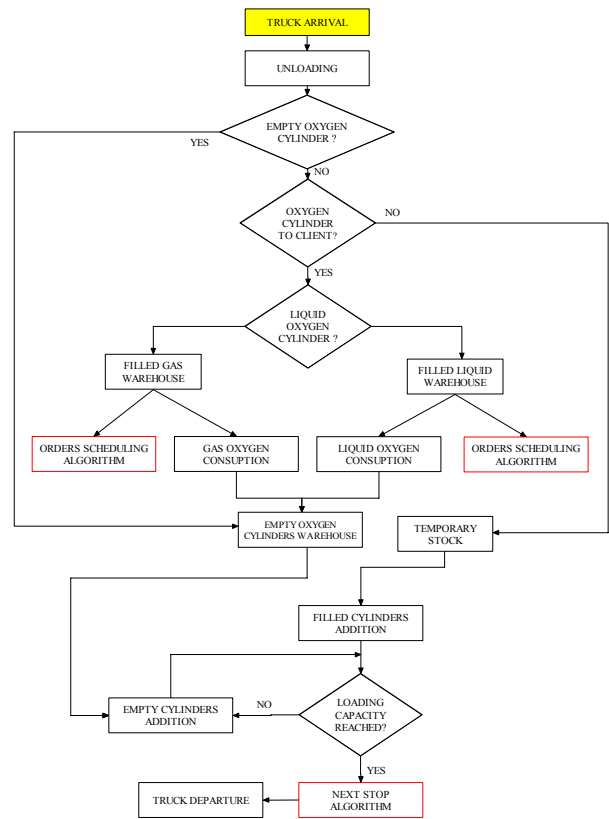

Fig 7 – Customer related processes

## PLANT AND DISTRIBUTION MODEL

The production plant is designed only in the activities that can influence distribution logistic. Production activity of cylinders is oriented to guarantee a certain level of stock. The finished product is assigned to a specific customer in the same sequence as the orders arrive. Then, the gathering of cylinders in load units and after in trucks is effectuated considering, already at this

stage, the final destination of the product, so to avoid many different deliveries to the same customer in short times. The effect is a bypass of FIFO order sequence adopted in the assignment of cylinders to customers to carry at the same time the amount of product of an order and all the short next. The logic frame is presented in fig. 8.

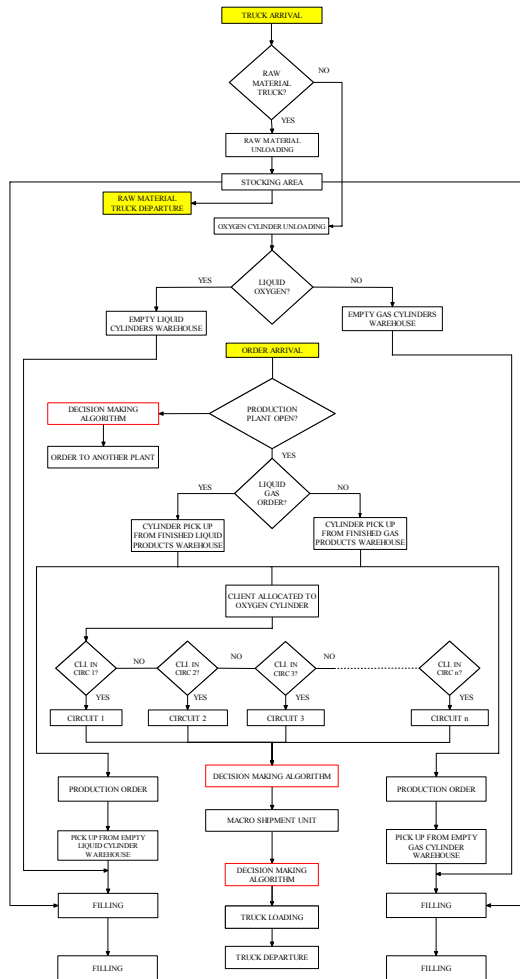

Fig. 8 – Production plant related process

About the grouping of orders based on their final destination, it is necessary to create circuits to link nearest, or easiest to reach, customers. Once chosen the customer to satisfy, according to waiting time of the assigned cylinder, all the product of the same circuit are loaded. After having verified the capacity on the truck, all the product of a different circuit are loaded. Each plant has default assigned circuits on a geographic criterion (fig. 9). On this allocation of customers in neighbour groups, the algorithm of distribution management and scheduling are implemented. Referring to bibliography study on models and algorithm in logistics, having to face an analytic close model with linear bounds, it was used a combination and integration of simulation with analytic techniques, realizing a tool operating on wide range.

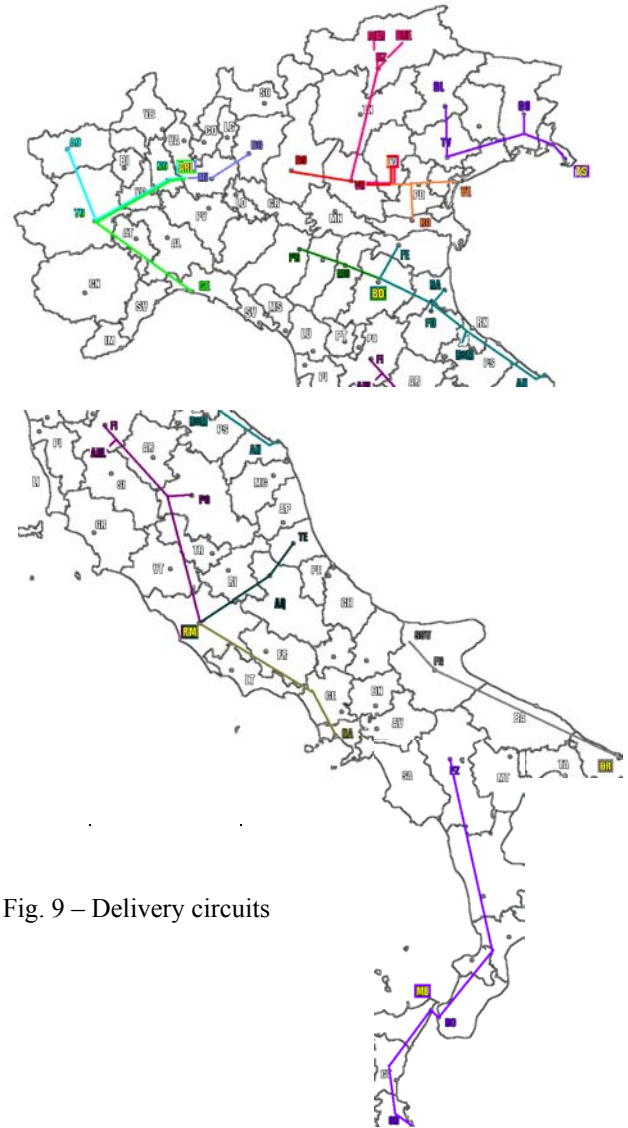

Fig. 9 – Delivery circuits

In particular, the problem regarded a dynamic directing of vehicles, known as Vehicle Routing Problem (VRP), or an optimization of load vectors and sequencing of visits for each vector, determining  $K$  routes, from a central station to a subset of customers in a specific sequence to minimize the global trip cost. VRP can be divided into the Traveller Salesman Problem (TSP), the research of the minimum route for a vector to visit all the customers in different cities, leaving and coming back to its base, and a Clustering Problem (CP), the assignment of customers to the single vectors. These activities have to be carried out considering:

- capacity bound: maximum number of part on the vector;
- time bound: maximum waiting time for orders.

So, it was chosen to implement a VRP algorithm composed by a first clustering step and a second routing step, in a greedy heuristic, where, starting from a knot of reference, the optimal sequence is constructed simply passing on the nearest knot. Therefore, if a circuit can't

complete load capacity of the correspondent vector, another circuit is chosen on delivery time bound, till a time or capacity bound is violated, so obtaining the cluster assigned. This activity is carried out inside the plant by the simulation model on constituting the load for each vector.

For each load unit in a truck, the distance between its destination and all the other destinations of the units already on is calculated. The entering unit is placed in the sequence when its distance is less than the distance that the same destination had. If this doesn't happen, the entering unit is so put at the end of the sequence. When, instead, the current unit is inserted in a sequence already existing, reasonably it creates changes that involve all the successive to the one of insertion; it's so necessary a greedy optimization procedure for the next visits (fig. 10). Furthermore, given the purpose of the study, an algorithm was implemented to allow, in case of closing of a plant, the redistribution of orders to another production site on the beginning of the allocation procedure.

### THE EXPERIMENT

The research analyzed the effects of supply chain configuration changes in delivering activities, in particular the closing of plants in the production and stocking net and the consequent new set up of customer service. The parameters of the simulation (invariant input) are:

- customers demand modelled as negative exponential distribution curve with characteristic value given by historical series analysis;
- maximum waiting time of orders (time in stock before delivery). In defining the value, it's to consider also a reasonable transport time to reach the end user: this highly affects the load of each leaving vector and, if too short, it can cause partially empty trucks. In this simulation experiments, considering the particular urgency of the product and the contractual clauses, it's fixed at 12 hours;

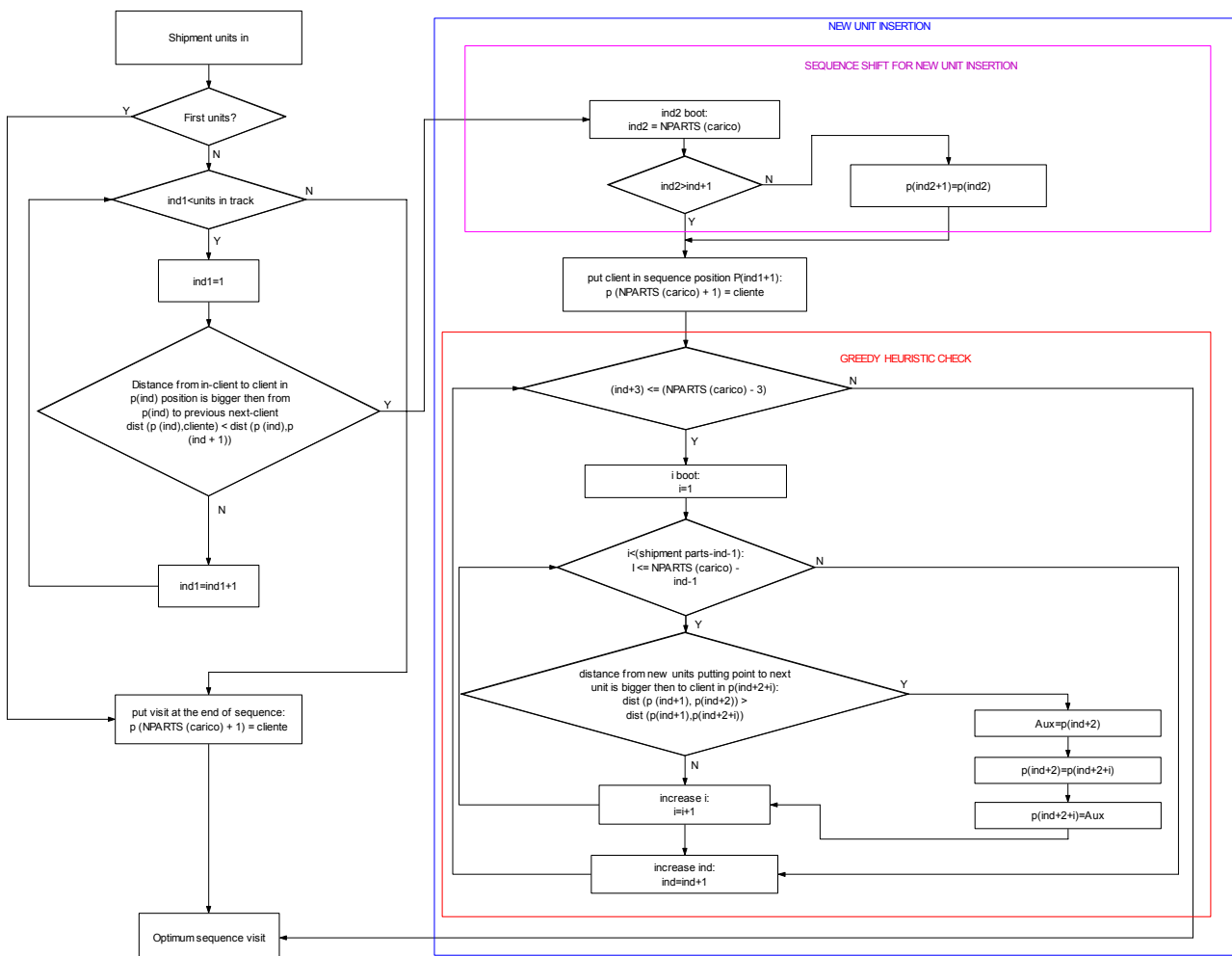

Fig. 10 – Routing algorithm flow chart

- production time and capacity. For the purpose of the study, they are taken in appropriate way to always guarantee the correct amount of product available with no delay.

The output results to analyze are the following:

- average waiting time for orders (average service time) for each customer;
- maximum waiting time (maximum service time) for all the customers;
- number of units transported by vehicles, relative to every production site, to estimate logistic costs;
- number of stock-outs.

The distribution activities is monitored in a campaign of runs of 62 consecutive days, long enough to smooth the transitory effect of the first supplies and give a regime solution.

#### Closing Rome plant

When a production site is closed, the reassignment procedure is automatically activated, shifting the orders to the still active plants, on a geographic criterion. All Rome's customers are diverted to Bologna, the nearest factory. To define the new situation, the service level offered to Naples is monitored, representing the most critical customer for Bologna, as it's the most distant. Figure 11 sums up the new situation, varying the number of active vectors related to the number of stock-outs generated, to the average waiting time and to the average number of loads on the truck. In table 1 Naples levels of performance, before and after Rome closing, are compared.

$\Delta_{A.W.T.}$  is the percentage variation of average waiting time related to the balanced starting situation.

As it can be seen in the table, average waiting time of Naples, even with an increase of 14 vectors in Bologna (only 5 were active before in Rome), worsen of 67%.

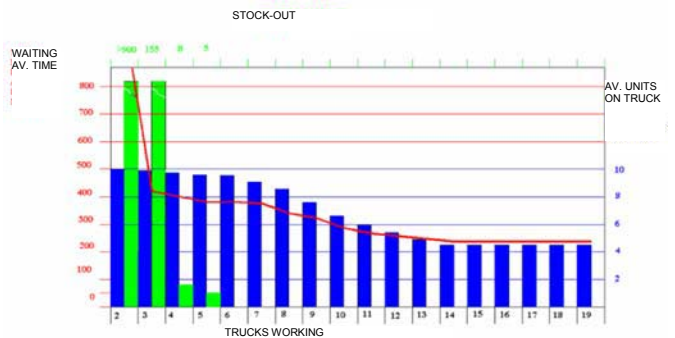

Fig. 11 – Summary of Bologna distribution and Naples service level

Any new vector doesn't allow an increase of level because, always respecting the maximum order wait bound, Naples is too far, so to limit inferiorly the average waiting time of the customer. In fact, there are physical bounds (distances) that prevent from having waiting average time lower than a certain value, as it's impossible to go below 7 hours if it needs 7 hours to reach Naples from Bologna.

With 6 vectors there is already no stock-out but the average waiting time becomes 17h 30m (387 time units), 176% higher than the balanced situation. Nevertheless a service distribution with only 6 vectors is notably more economic, not only for a lower number of vehicles acquired and the related costs (maintenance, consumption, drivers, etc.) but also because they generally travel with 9,52 load units instead of 4,59 in case of 14 vectors, the best service level situation. The maximization of marginal unit, 25%, is obtained passing from 8 to 9 trucks.

Tab. 1 – Comparison of Naples service levels before and after Rome closing

NAPLES								
	All open	Rome closed						
	served by Rome	served by Bologna						
N° trucks	5	2	3	4	5	6	7	8
Av. waiting time	140	///	430	400	390	387	380	370
$\Delta_{A.W.T.}$		///	205%	187%	178%	176%	170%	164%
Av. shipment	5.40	10	9.88	9.74	9.56	9.2	8.2	7.01
N° trucks		9	10	11	12	13	14	15
Av. waiting time		330	320	290	260	240	235	235
$\Delta_{A.W.T.}$		135%	128%	107%	85%	71%	67%	67%
Av. shipment		6.19	5.5	5.02	4.7	4.63	4.59	4.57
N° trucks		16	17	18	19	20		
Av. waiting time		235	235	235	235	236		
$\Delta_{A.W.T.}$		67%	67%	67%	67%	67%		
Av. shipment		4.57	4.57	4.57	4.57			

Considering that the number of vectors of Bologna in the balanced scene is 2, it's to face that without an empowerment of resources the distribution system falls in crisis: each customer has a stock-out and the average waiting time for Naples surpasses 40h. Even acquiring a further truck the situation doesn't improve, with 155 stock-outs in the simulation time. Furthermore, the average waiting time is still at an unacceptable level of 30h.

**Closing Bologna plant**

After having closed Bologna site, the algorithm reassigns Parma customer to Arluno plant and Modena, Ferrara, Ravenna, Forlì, San Marino to Vicenza.

After having balanced the production, San Marino service level is analyzed in the new situation, representing the most critic customer as the most distant (fig. 12). In table 2 San Marino service level is shown, in the two cases of Bologna and Vicenza assignment.

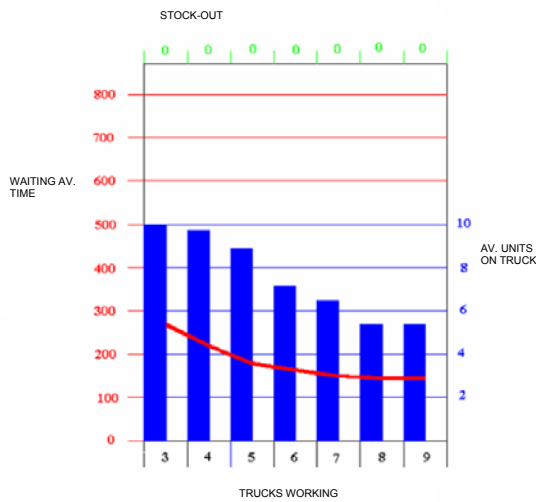

Fig. 12 – Summary of Vicenza distribution and San Marino service level

As it can be noticed, the number of vectors owned by Vicenza in standard situation is sufficient to obtain a service level without stock out.

Increasing the number of vehicles, the improvement of average waiting time goes in a linear way to arrive at

the same level of standard Bologna assignment, with an equipment of 8 vectors that almost double the initial park. Nevertheless this new balanced situation, transport costs are sensibly higher as the average load, in fact, is lower, passing from 8 to 5,6 units.

**Rome and Bologna site closing**

After the closing of Rome and Bologna, they become both customer of the resulting net. The geographic criterion reassigns Teramo and L'Aquila to Brindisi, Firenze, Certaldo, San Marino, Ravenna, Ferrara, Forlì, Modena, and Roma to Vicenza, Parma to Arluno, Napoli to Reggio Calabria.

Rome customer is described as a significant example (fig. 13), representing the most critical customer as the most distant from Vicenza.



Fig. 13 – Summary of Vicenza distribution and Rome service level

At this point, the comparison in table 3 shows two different cases:

- closing of Rome site and subsequent assignment of Rome customer to Bologna;
- closing of both Rome and Bologna and subsequent assignment to Vicenza.

The passage of Rome customer from Bologna to Vicenza causes a general increase in average waiting time, highly varying with the number of trucks considered. For levels of about 15h (330 time units and 8 vectors), the difference between the two scenes is sensibly lower than what happens on higher levels (less than 14h), as seen in figure 14.

Tab. 2 – Comparison of San Marino service levels before and after Bologna closing

SAN MARINO								
	All open	Bologna closed						
	(served by Bo)	(served by Vicenza)						
N° trucks	5	3	4	5	6	7	8	9
Av. waiting time	140	260	230	180	160	150	140	140
$\Delta_{A.W.T}$		85%	65%	28%	14%	7%	0%	0%
Av. shipment	8	10	9.67	9.68	7.35	8.8	6.5	6.5

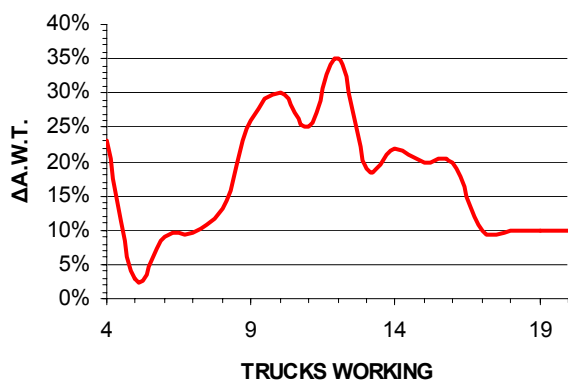

Fig. 14 – Percentage difference on Rome service level of Bologna and Vicenza

After 10 trucks, the value decreases and stabilize at 10%, as the service level depends no more on production site capacity but only on the distance of the two cities.

A global analysis of the results obtained in the simulation runs determines that a site closing always worsens total service level, even more sensibly when the new assignment allocates together distant customers and plants. Closing Rome and guaranteeing a good service level (average waiting time of 14h for the most critic customer) needs an acquisition of at least 8 vectors. The reason of this big increase is that Bologna has to serve 6 clients very far one from the other, someone also from the plant. To confirm what supposed, closing Rome and Bologna creates an increase of 9 customers in Vicenza, but to obtain a service level of 14h for the most critic one it needs only

4 more vectors: the clients assigned to Vicenza are in fact easier to reach and more concentrated by the site. This is more evident analyzing the closing of Bologna that redirects 6 customers to Vicenza, being anyway able to react properly to this new incoming traffic with its vehicles and establishing the standard situation with only 4 more.

### CONCLUSION AND FUTURE RESEARCH

Simulation study showed that, on deliveries point of view, sites with very few customers, if distant, are anyway important to maintain an high service level, more than highly productive factories with many customers but near to other production centres. This means the necessity of having sites opened only for their strategic geographic location even with a not so relevant production.

The decision support system is in its first stage, as it has many further development not already considered:

- after having closed all the production sites and leaving only primary factory, an analysis can be carried out to fix an optimal stock level for each customer, to avoid at best stock outs and minimizing immobilization costs;
- on the same stage, it's possible to define a reorder level for raw materials to avoid production stops and minimize immobilization costs;
- a costs – benefits analysis can be implemented. The natural development of the model allows not only to investigate effects on service level caused by the closing of a production centre, but to completely evaluate its economic impact on company general behaviour;

Tab. 3 – Comparison of Rome service levels before and after Bologna closing

ROME										
Served by Bologna						Served by Vicenza				
3	4	5	6	7	N° trucks	3	4	5	6	7
410	380	340	320	310	Av. Waiting time	///	470	350	350	340
					Δ <sub>A.W.T.</sub>		23%	3%	9%	9.6%
					equal trucks number					
10	9.9	9.81	9.69	9.27	Av. shipment	10	9.88	9.86	9.65	9.34
8	9	10	11	12	N° trucks	8	9	10	11	12
290	260	240	235	215	Av. Waiting time	330	330	310	300	290
					Δ <sub>A.W.T.</sub>	13%	26%	30%	25%	35%
					equal trucks number					
8.4	7.5	6.5	6	5,5	Av. shipment	9.05	8.45	7.87	7.04	6.32
13	14	15	16	17	N° trucks	13	14	15	16	17
210	200	200	200	200	Av. Waiting time	250	245	240	220	220
					Δ <sub>A.W.T.</sub>	19%	22%	20%	10%	10%
					equal trucks number					
4.9	4.5	4.5	4.5	4.5	Av. shipment	5.7	5.25	5.25	4.79	4.52

- tests on different ordering policies for customers are easily designable, increasing their stock level and delivering more than a truck at the same time;
- the simulation tool can be easily refined introducing production programs and activities with the logics related with distributive system. It would be possible to analyze overloads of factories after an increase in their number of customers and the necessary action to prevent (empowerment of production line resources or new investments in capacity). Furthermore, the effects of production stops on customers and the way to react to crisis simulation could be investigated.

It's also remarkable that the modularity of the model allows an easy adaptability to any different supply chain situation. Considering that it's mainly based on a distance matrix loaded at start, any different logistic scene can be implemented.

## REFERENCES

- Archibal G., Karabakal N., (1999), Supply Chain vs. Supply Chain: Using Simulation to Complete Beyond the Four Walls, Iwinter Simulation Conference.
- Bodin L., Golden B., Assad A., (1983), Routing and scheduling of vehicles and Crews: the state of art, Computer Operation Research n°10, pp 63-212.
- Bresnahan J., (1998), The incredible journey - supply chain anatomy, CIO Enterprise Magazine, August 15 1998, p 5-6.
- Banks J. et al (1998), Handbook of Simulation, John Wiley and Sons, New York.
- Haskett J. L., (1973), Macroeconomic Cost of Physical Distribution, ATRF, 1962 and Haskett and others, Business Logistics (2nd ed).
- Hillier F. S., Lieberman G. J., (2001), Introduction to operations research, McGraw-Jill, pp 350-403.
- Lambert D., Stock J., (2001), Strategic Logistic Management, McGraw-hill, New York.
- Law A., Kelton B.,(2000), Simulation modelling and analysis, McGraw-Hill, New York.
- Nozick L. K., Turnquist M. A., (1998), Integrating inventory impacts into a fixed-charge model for locating distribution centers, Transportation Research E, Vol.34, 173-186.
- Nozick L. K., Turnquist M. A., (2001), A two-echelon inventory allocation and distribution center location analysis, Transportation Research E, Vol.37, 425-441.
- Okumura M., Tsukai M, (2003), Distribution Network Configuration Considering Inventory Cost, 43rd Congress of the European Regional Science Association, University of Jyväskylä, Finland.
- Pedgen, Shannon, Sadowsky, (1995), Introduction with simulation using Simann, McGraw-Hill, New York.
- Russel R. S., Taylor III B. W., (2000), Operations Management, Prentice-Hall, pp 371-422.
- Schiber, (1990), Introduction to simulation using GPSS-H, John Wiley and Sons, New York.
- Van Breedam A., (2001), Comparing descent heuristics and metaheuristics for the vehicle routing problem, Computers Operations Research, n°28, pp 289-315.

## AUTHOR BIOGRAPHIES

**FRANCESCO COSTANTINO**, degree in mechanical engineering and master in quality engineering and management, is currently a Ph.D. student in industrial production engineering at the University of Rome "La Sapienza".

His e-mail address is: francesco.costantino@uniroma1.it

**GIULIO DI GRAVIO**, degree in mechanical engineering and master in quality engineering and management, is currently a Ph.D. student in industrial production engineering at the University of Rome "La Sapienza".

His e-mail address is: giulio.digravio@uniroma1.it

**MASSIMO TRONCI**, degree in mechanical engineering and Ph.D. in energetics, is an ordinary professor of industrial plants, operation management and quality management at the University of Rome "La Sapienza", faculty of engineering, full member of EOQ as vice-president of AICQ (Italian Organization for Quality).

His e-mail address is : massimo.tronci@uniroma1.it